

# EKL-455MT

EKL-SERIES



## SPECIFICATION

POWER SUPPLY	220V., 60HZ., 3-PHASE ; 400V., 50HZ., 3-PHASE
MAX. CONSUMPTION POWER	9Kw
SEALING DIMENSION	400mm (W) X 550mm (D)
TUNNEL INLET DIMENSION	400mm (W) X 200mm (H)
MAX. FILM ROLL DIMENSION	600mm X Ø300mm
WORKING PLATE HEIGHT	900mm
MACHINE DIMENSION	2570mm (L) X 870mm (W) 1600mm (H)
MAX. PACKING HEIGHT	150mm
MACHINE WEIGHT	400Kg

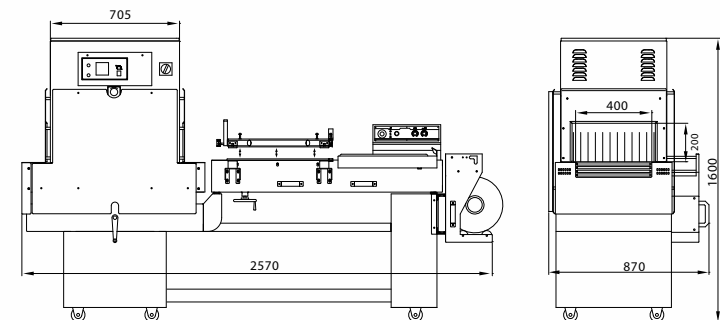

**SITCO**  
TOTAL PACKAGING SOLUTIONS

شركة الفصول للتجارة والصناعة الدولية

SEASON INTERNATIONAL TRADING & INDUSTRIES CO.

P.O. Box 886, Manama - Kingdom of Bahrain, Tel: +973 17704647, Fax: +973 17704648  
E-mail: info@seasoninternational.net, web: www.seasoninternational.net