

# EXC-103TB

EXC-SERIES

## SPECIFICATION

TAPE WIDTH	1 1/2", 2"
BELT SPEED	23 METERS/MINUTE
CAPACITY	(L) 120mm - □ (W) 150mm - 500mm, (H) 120mm - 500mm
POWER SUPPLY	100/110/220/230/240V., 50Hz/60Hz., 1-Phase
POWER CONSUMPTION	450W

## OPTION

3" Tape head

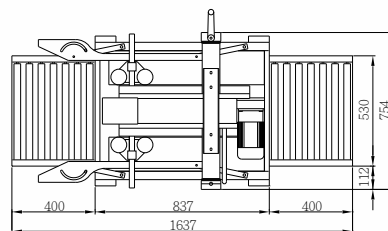
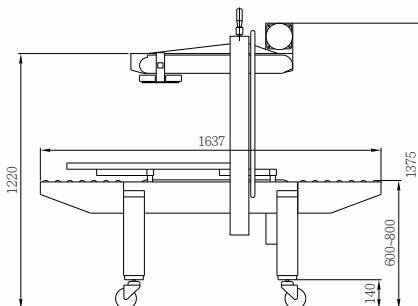

**SiTCO**  
TOTAL PACKAGING SOLUTIONS

شركة الفصول للتجارة والصناعة الدولية

SEASON INTERNATIONAL TRADING & INDUSTRIES CO.

P.O. Box 886, Manama - Kingdom of Bahrain, Tel: +973 17704647, Fax: +973 17704648  
E-mail: info@seasoninternational.net, web: www.seasoninternational.net