

# EKT-525/630

EKT-SERIES

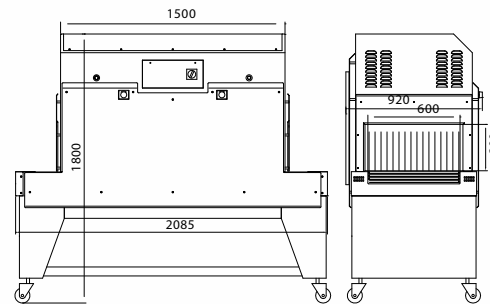
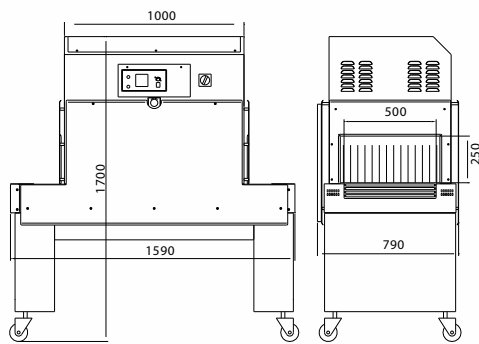

## SPECIFICATION

POWER SUPPLY  
MAX. POWER CONSUMPTION  
TUNNEL INLET  
MACHINE DIMENSION  
MACHINE WEIGHT

## EKT-525

220V., 60HZ., 3-PHASE ; 400V., 50HZ., 3-PHASE  
9Kw  
500mm (W) X 250mm (H)  
1590mm (L) X 790mm (W) X 1700mm (H)  
305Kg

## EKT-630

220V., 60HZ., 3-PHASE ; 400V., 50HZ., 3-PHASE  
18Kw  
600mm (W) X 300mm (H)  
2085mm (L) X 890mm (W) X 1800mm (H)  
485Kg

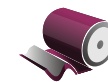

**SiTCO**  
TOTAL PACKAGING SOLUTIONS

شركة الفصول للتجارة والصناعة الدولية

SEASON INTERNATIONAL TRADING & INDUSTRIES CO.

P.O. Box 886, Manama - Kingdom of Bahrain, Tel: +973 17704647, Fax: +973 17704648  
E-mail: info@seasoninternational.net, web: www.seasoninternational.net